

D.C. Motor

Simplified SPICE Model

Contents

1. Benefit of the Model
2. Model Feature
3. Parameter Settings
4. D.C. Motor Specification (Example)
5. Motor Start Up Simulation at Normal Load
6. Motor Start Up Simulation at Half of Normal Load
7. L_j of the Motor Model (1/2)
8. Application Example
9. Winding Characteristic Parameters: L_m
10. Winding Characteristic Parameters: R_m

Simulation Index

1. Benefit of the Model

- The model enables circuit designer to use D.C. Motor as load in their design which include: Back EMF, Torque(N·m) and Speed (rpm) characteristics.
- The model can be easily adjusted to your own D.C. Motor specifications by editing a few parameters that are provided in the spec-sheet.

2. Model Feature

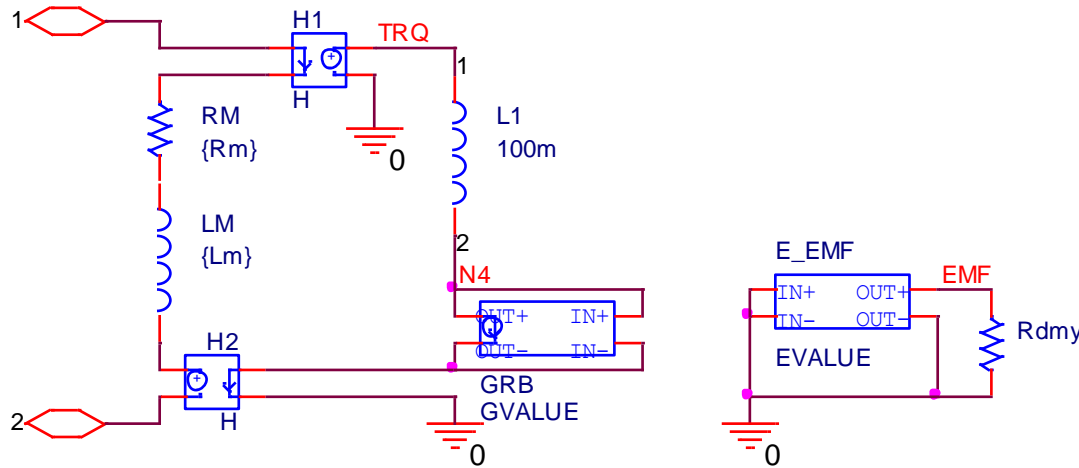

Equivalent circuit of the D.C. Motor model

- This *D.C. Motor Simplified SPICE Model* is for users who require the model of D.C. Motor as a part of their system.
- Perform electrical (voltage and current) and mechanical (speed and torque) characteristics at current load (Ampere) conditions.

3. Parameter Settings

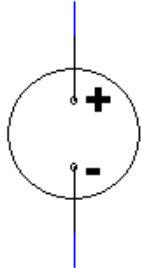

U1

SMPL_DC_MOTOR

Rm=0.1 Lm=100u Lj=100m

V_norm=7.2 mNm=19.6 kRPM_norm=14.4 I_norm=6.1

IL=6.1

D.C. Motor model and Parameters with Default Value

Model Parameters:

If there is no measurement data, the default value will be used:

Rm: motor winding resistance [Ω]

Lm: motor winding inductance [H]

Data is given by D.C. motor spec-sheet:

V_norm: normal voltage [V]

mNm: normal load [$\text{mN}\cdot\text{m}$]

kRPM_norm: speed at normal load [kr/min]

I_norm: current at normal load [A]

Load Condition:

IL: load current [A]

4. D.C. Motor Specification (Example)

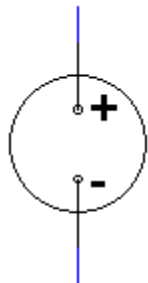

U1
SMPL_DC_MOTOR
Rm=0.1 Lm=100u Lj=100m

V_norm=7.2 mNm=19.6 kRPM_norm=14.4 I_norm=6.1

IL=6.1

D.C. Motor Specification
Parameters are input



RS-540SH-6527
性能表

- 使用電圧範囲 (Voltage Range) 4.5~9.6V
- 適正電圧 (Normal Voltage) 7.2V
- 適正負荷 (Normal Load) 19.6mN·m(200gf·cm)
- 無負荷回転数 (Speed at No Load) 15,800r/min
- 適正負荷時の (At Normal Load)
 - 回転数 (Speed) 14,400r/min
 - 消費電流 (Current) 6.1A
- シャフト径 (Shaft Diameter) 3.17mm

性能は定電圧電源使用にもとづく (Specification with Constant Voltage Supply)

マブチモーター株式会社
日本国内向け製品 (For sale only in Japan)

 モーター袋と
ビス袋: PE

 外箱
緩衝材は
段ボール

5. Motor Start Up Simulation at Normal Load (1/2)

Simulation Circuit and Setting

```
.PARAM VOUT=10.25 Rs=0.5
```

Input the Supply *No Load Voltage** and *Series Resistance*

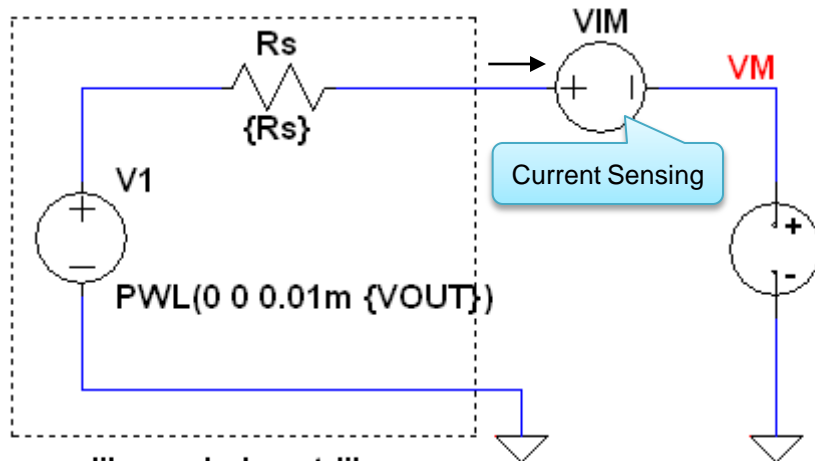

Simplified D.C. Motor with RS-540SH Spec.

```
U1  
SMPL_DC_MOTOR  
Rm=0.1 Lm=100u Lj=100m  
V_norm=7.2 mNm=19.6 kRPM_norm=14.4 I_norm=6.1  
IL=6.1
```

Load Condition $I_L = I_{norm}$

```
.lib smpl_dc_mt.lib  
.tran 0 400m 0 0.1m
```

*No Load Voltage is adjusted until the D.C. motor voltage (VM) equals to the normal voltage (7.2V).

*Analysis directives:

```
.TRAN 0 400m 0 0.1m
```

```
.PROBE V(*) I(*) W(alias(*)) D(alias(*)) NOISE(alias(*))
```

5. Motor Start Up Simulation at Normal Load (2/2)

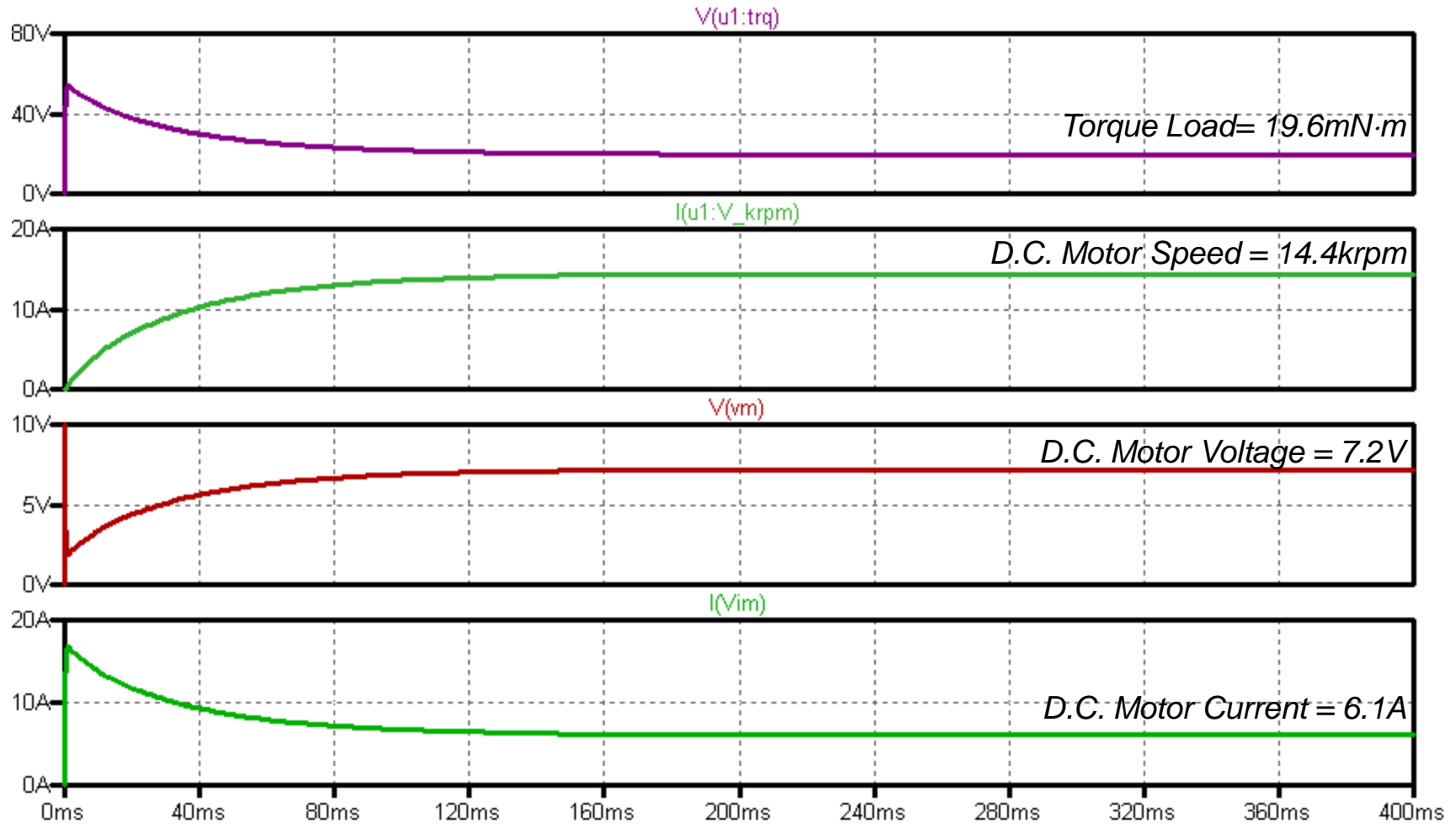

6. Motor Start Up Simulation at Half of Normal Load (1/2)

Simulation Circuit and Setting

```
.PARAM VOUT=10.25 Rs=0.5
```

Input the Supply No Load Voltage* and Series Resistance

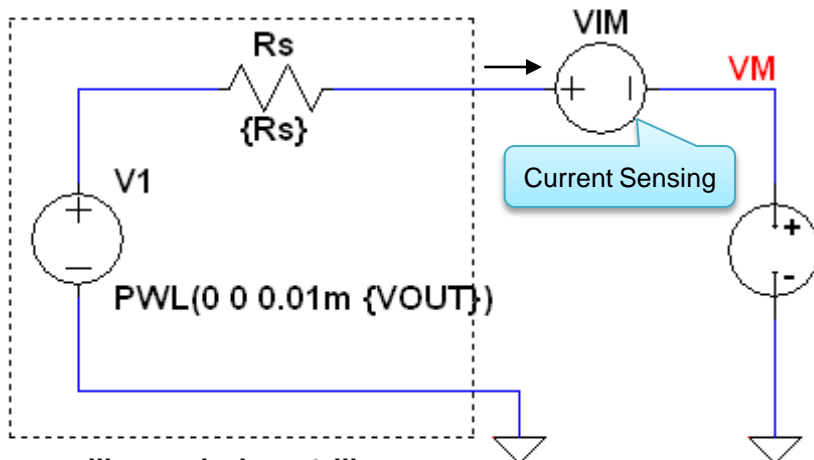

Simplified D.C. Motor with RS-540SH Spec.

```
U1  
SMPL_DC_MOTOR  
Rm=0.1 Lm=100u Lj=100m  
V_norm=7.2 mNm=19.6 kRPM_norm=14.4 I_norm=6.1  
IL=3.05
```

Load Condition $I_L = I_{norm}$

```
.lib smpl_dc_mt.lib  
.tran 0 400m 0 0.1m
```

*No Load Voltage is adjusted until the D.C. motor voltage (VM) equals to the normal voltage (7.2V).

*Analysis directives:

```
.TRAN 0 400m 0 0.1m
```

```
.PROBE V(*) I(*) W(alias(*)) D(alias(*)) NOISE(alias(*))
```

6. Motor Start Up Simulation at Half of Normal Load (2/2)

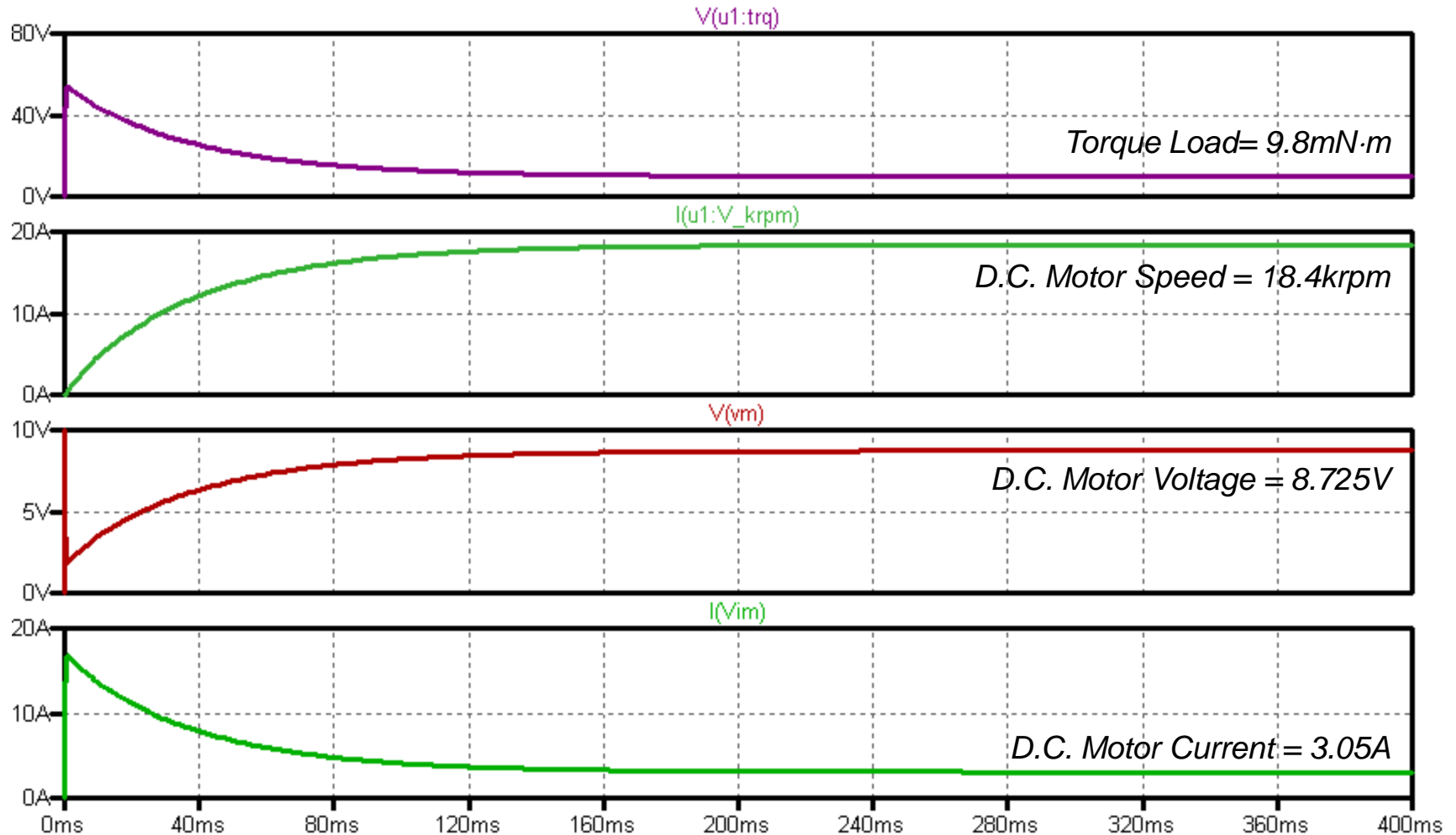

7. Lj of the Motor Model (1/2)

Simulation Circuit and Setting

.PARAM VOUT=10.25 Rs=0.5

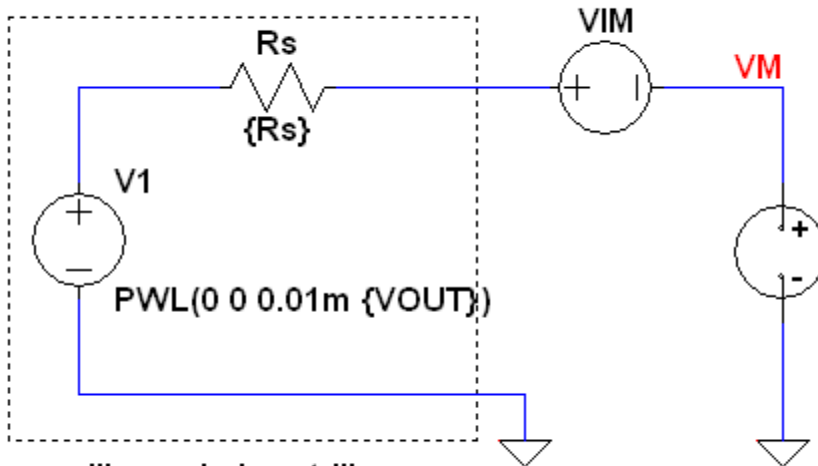

Input the Lj value or input "{Lj}" for parametric sweep

U1
SMPL_DC_MOTOR
Rm=0.1 Lm=100u Lj={Lj}
V_norm=7.2 mNm=19.6 kRPM_norm=14.4 I_norm=6.1
IL=6.1

```
.lib smpl_dc_mt.lib  
.tran 0 400m 0 0.1m  
.STEP PARAM Lj LIST 100m, 200m
```

*Analysis directives:
.TRAN 0 400m 0 0.1m
.STEP PARAM Lj LIST 100m, 200m

7. Lj of the Motor Model (2/2)

The Motor Start-up Waveform is changed by the Lj values.

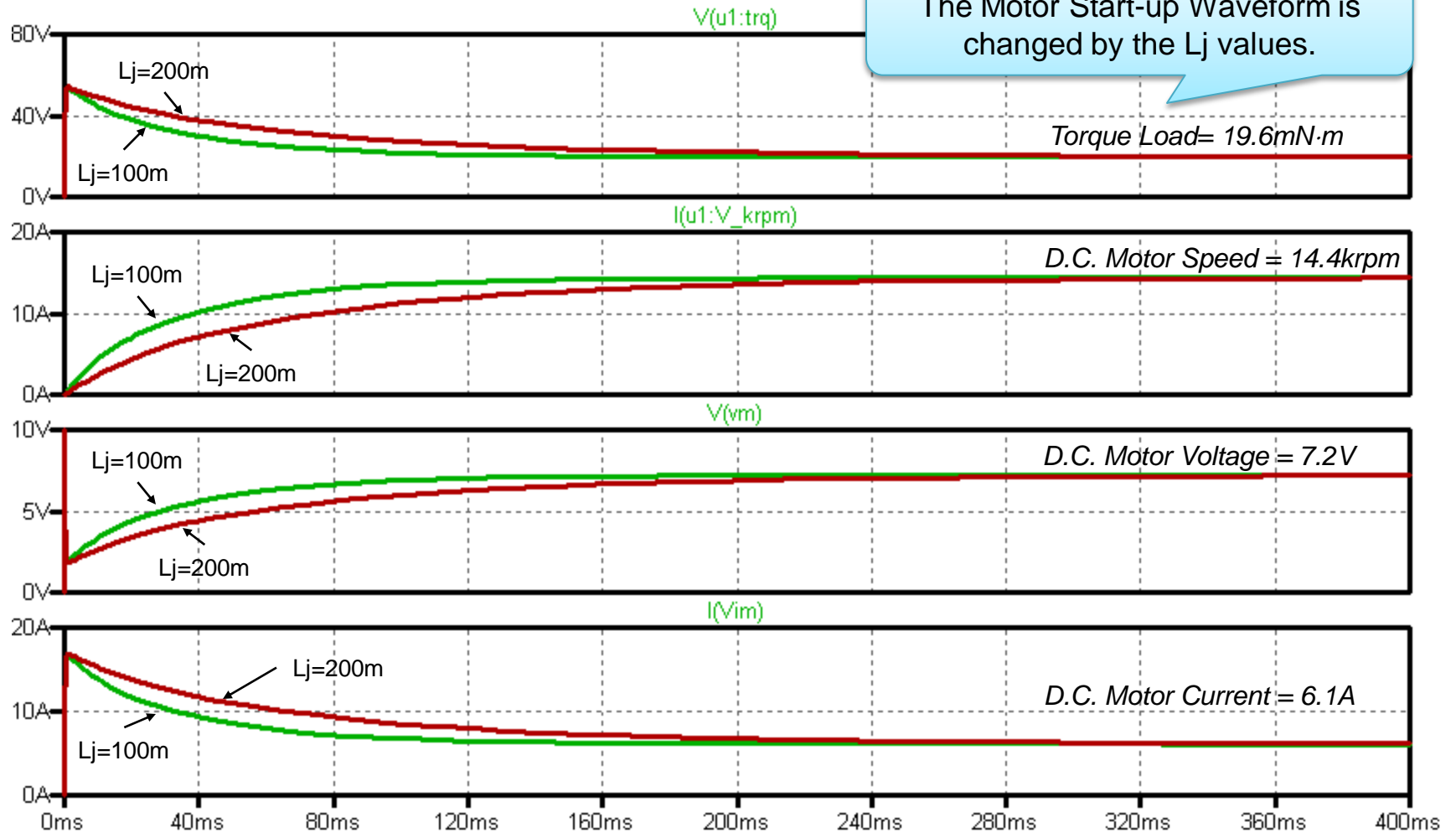

8. Application Example (2/3)

Measurement

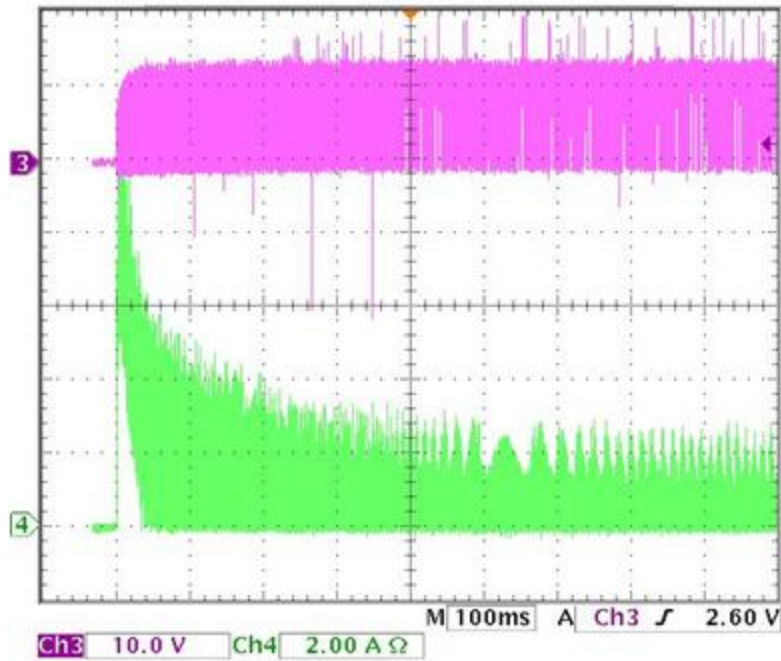

Simulation

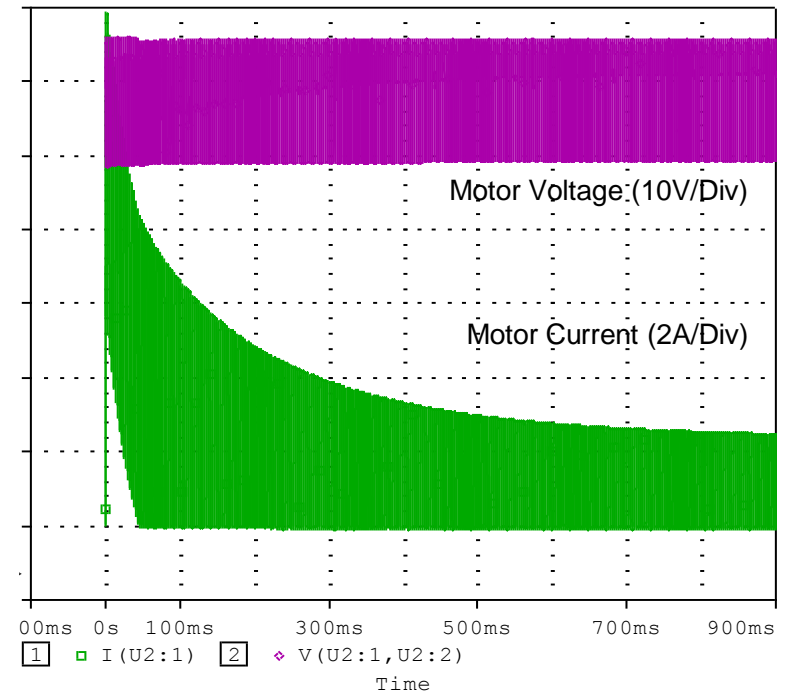

8. Application Example (3/3)

Measurement

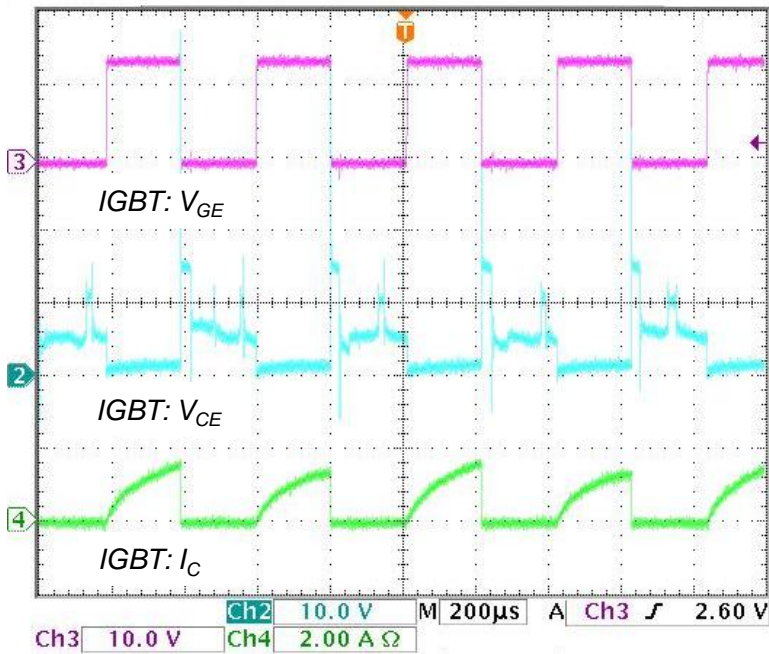

Simulation

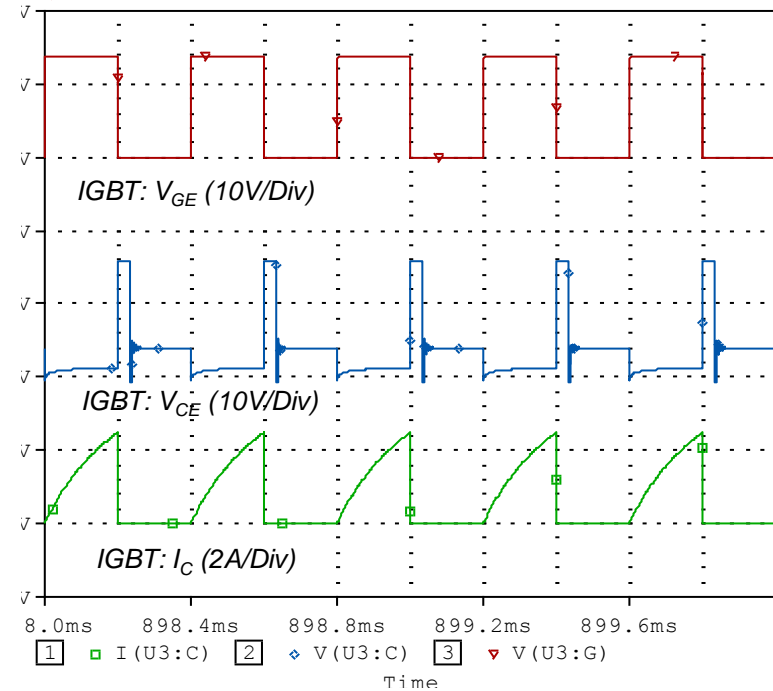

9. Winding Characteristic Parameters: Lm

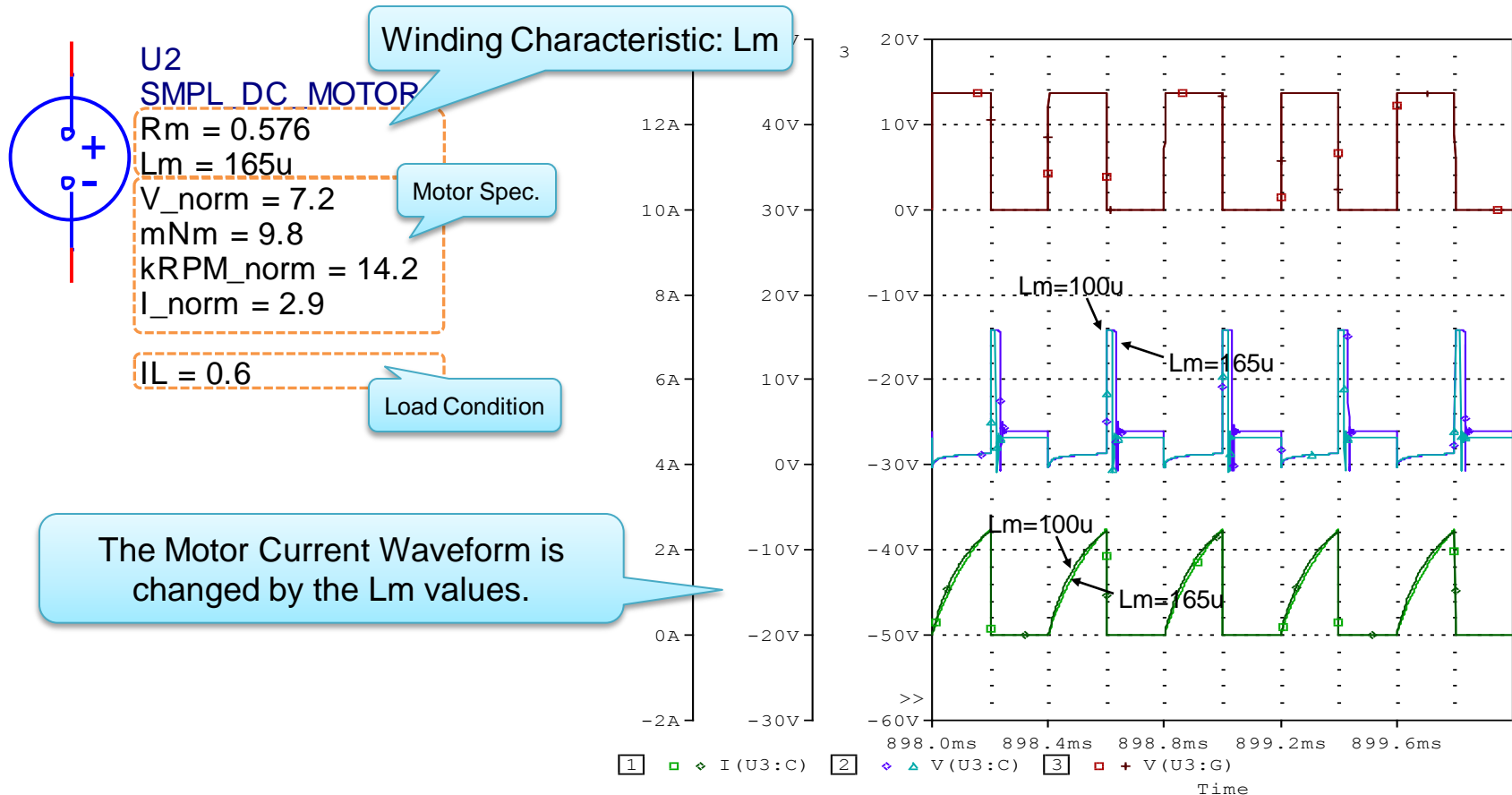

10. Winding Characteristic Parameters: Rm

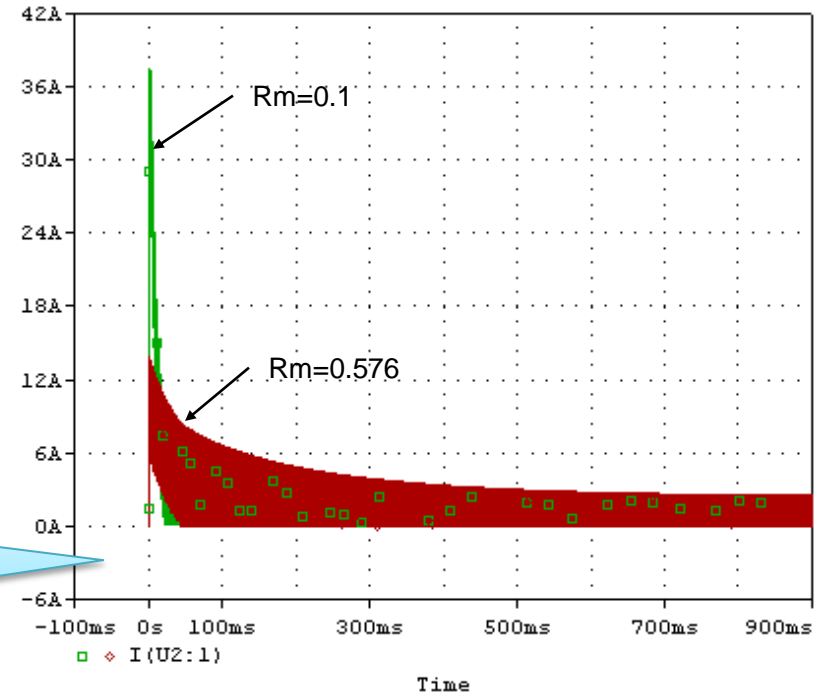
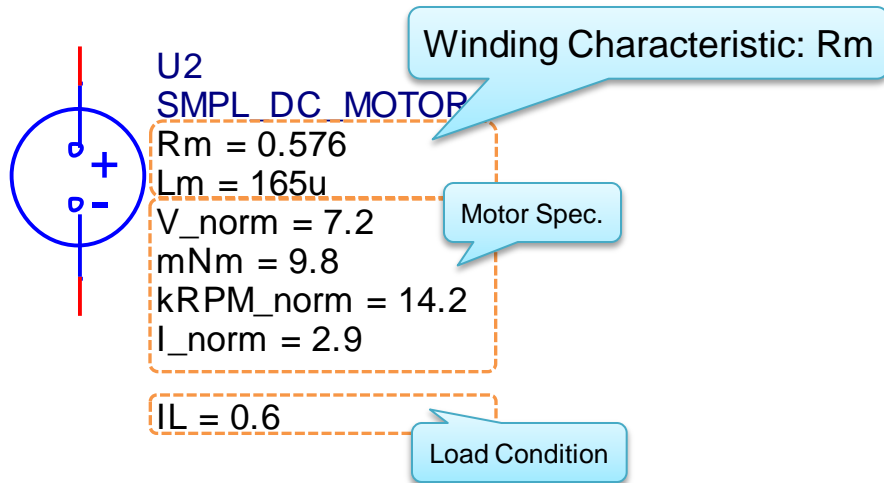

The Motor Start-up is Current changed by the Rm values.

Simulation Index



Simulations	Folder name
1. Motor Start Up Simulation at Normal Load.....	Normal
2. Motor Start Up Simulation at Haft of Normal Load.....	Half
3. Lj of the Motor Model.....	Lj