

Concept Kit 3-Phase AC Motor Drive Simulation For Electric Drive Systems [LTspice Version]

	Slide #
1. Modeling of 3-Phase AC Motor Model	
1.1 Manufacturer Specification.....	3
1.2 Torque and Back-EMF.....	4
1.3 Simplified 3-Phase AC Motor Model.....	5
1.4 The 3-Phase AC Motor Equivalent Circuit.....	6
1.5 Parameter Settings.....	7
2. Simulation Circuit of 3-Phase AC Motor Model.....	8
2.1 Phase Current Characteristics Under Load Variation.....	9
2.2 Back-EMF Characteristics Under Load Condition.....	10
2.3 Speed and Torque Characteristics At 140Arms.....	11
Appendix A: Measured Point of Simulation Circuit (1/2).....	12
Appendix A: Measured Point of Simulation Circuit (2/2).....	13
Appendix B: Evaluation Text.....	14
Appendix C: Gate Signal for Six-Step Control.....	15
Appendix D: 3-Phase AC Motor Model Text (1/2).....	16
Appendix D: 3-Phase AC Motor Model Text (2/2).....	17
Appendix E: Simulation Settings.....	18

1.1) Manufacturer Specification

Motenergy, Inc (ME0913)

Motor Electrical Parameters

- Operating Voltage Range.....0 – 72 V_{MAX}
- Rated Continuous Current.....140 Arms
- Peak Stalled Current.....400 Arms
- Voltage Constant.....50 RPM/V
- Phase Resistance (L-L).....0.0125 Ω
- Phase Inductance.....105uH at 120Hz, 110uH at 1kHz
- Maximum Continuous Power Rating.....17KW at 102V_{DC} Battery Voltage
14.3KW at 84V_{DC} Battery Voltage
12KW at 72V_{DC} Battery Voltage

Motor Mechanical Parameters

- Rated Speed.....3000 RPM
- Maximum Speed.....5000 RPM
- Rated Torque.....288 Lb-in
- Torque Constant.....1.6 Lb-in/A

1.2) Torque and Back-EMF

- The Torque are defined by :

$$\left. \begin{aligned} T_u &= KT \cdot I_u \\ T_v &= KT \cdot I_v \\ T_w &= KT \cdot I_w \end{aligned} \right\} \quad (1)$$

$$T_e = T_u + T_v + T_w \quad (2)$$

At 140Arms (Rated Continuous Current)

$$K_T = 1.6 \text{ Lb-in/A}$$

$$T_{phe} = 1.6 \cdot 140 = 224 \text{ Lb-in}$$

$$T_e = 224 \cdot 3 = 672 \text{ Lb-in}$$

- The Back-EMF are defined by :

$$\left. \begin{aligned} E_u &= KE \cdot \omega_m \\ E_v &= KE \cdot \omega_m \\ E_w &= KE \cdot \omega_m \end{aligned} \right\} \quad (3)$$

At 5000 RPM (Maximum Speed)

$$E_{phe} \approx V_{BAT} \quad (\text{In an ideal motor, R and L are zero})$$

$$E_{phe} = 102 \text{ V}$$

$$K_E = E_{phe} / \omega_m = 102 / 5000$$

$$K_E \approx 0.02 \text{ V/RPM}$$

※ **phe** : u, v, w

V_{phe} : Phase voltage applied from inverter to motor

V_{AC} : Operating voltage range (Maximum voltage)

V_{BAT} : DC Voltage applied from battery

I_{phe} : Phase current

T_{phe} : Electric torque produced by u, v, w phase

T_e : Electric torque produced by motor

E_{phe} : Phase Back-EMF

KE : Back-EMF constant

KT : Torque constant

ω_m : Angular speed of rotor

※ 1 Pound Inch equals 0.11 Nm

1.3) Simplified 3-Phase AC Motor Model

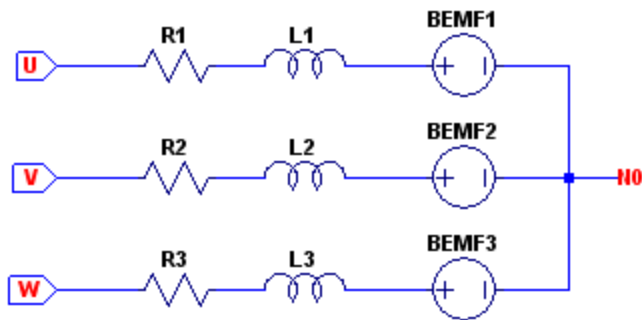
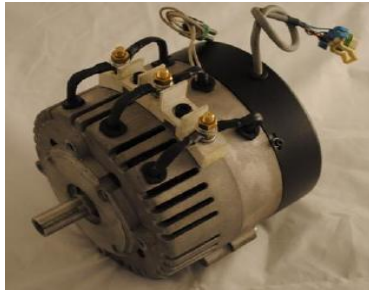

Fig. 1 Scheme of the 3-Phase Model

Frequency Response

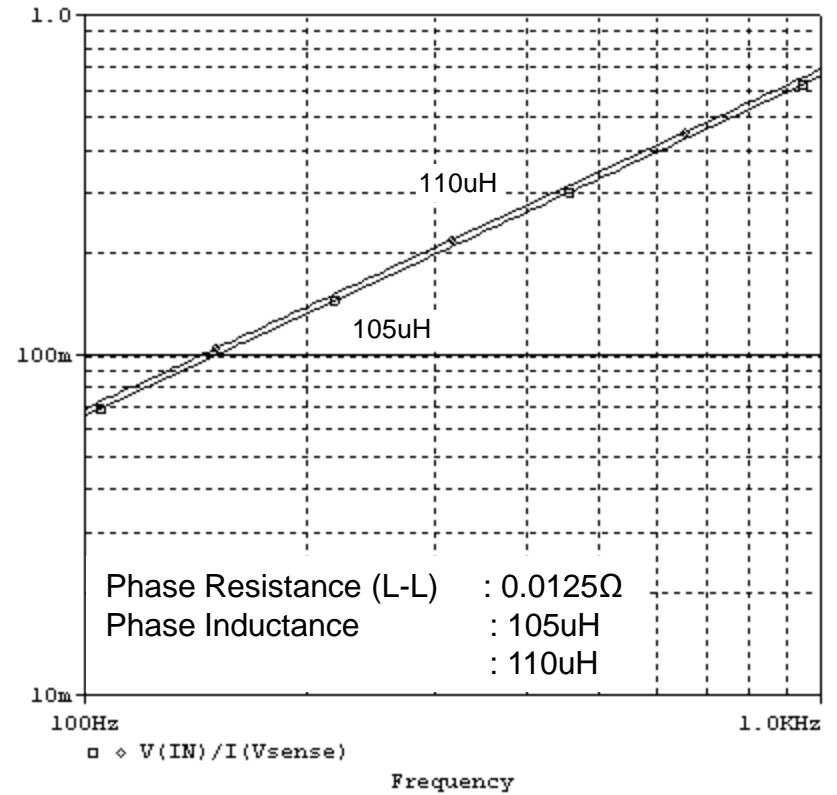

Fig.2 Phase-to-Ground

1.4) The 3-Phase AC Motor Equivalent Circuit

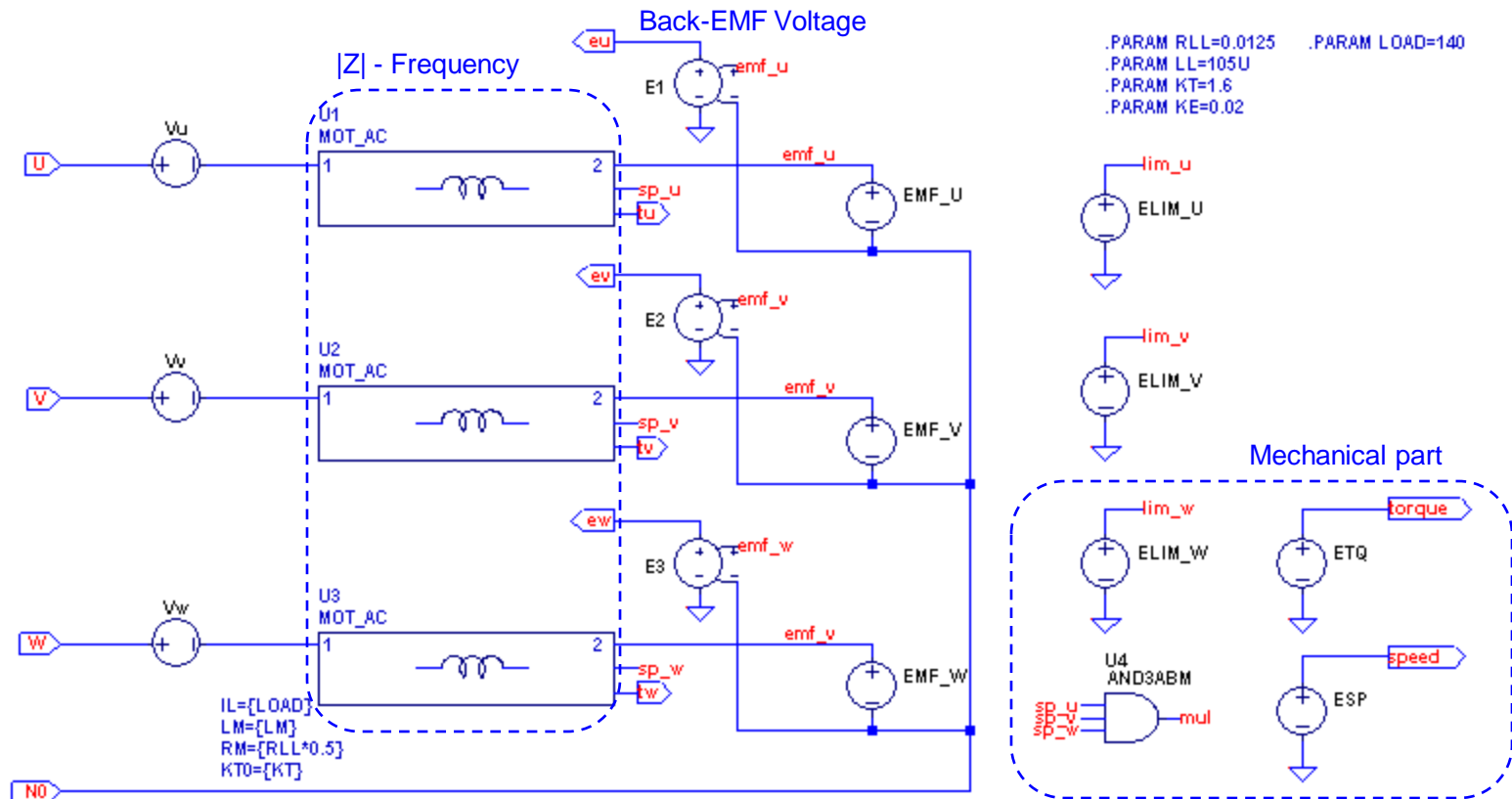

Fig. 3 Three-Phase AC Motor Equivalent Circuit

- This figure shows the equivalent circuit of AC motor model that includes the $|Z|$ -frequency part, Back-EMF voltage part, and Mechanical part.
- The Back-EMF voltage is the voltage generated across the motor's terminals as the windings move through the motor's magnetic field.

1.5) Parameters Settings

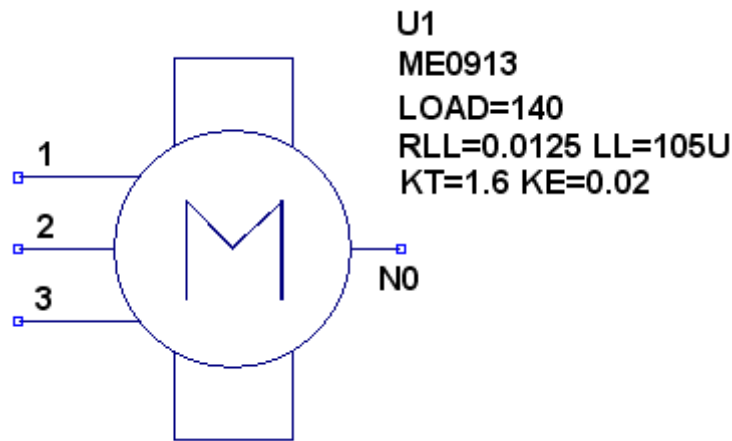

Fig. 4 Symbol of 3-Phase Induction Motor

Model Parameters:

LOAD : Load current each phase of motor [Arms]

- e.g. LL = 125Arms, 140Arms, or 400Arms

LL : Phase inductance [H]

- e.g. LL = 10mH, 100mH, or 1H

RLL : Phase resistance (Phase-to-phase) [Ω]

- e.g. RLL = 10m Ω , 100m Ω , or 1 Ω

KE : Back-EMF constant [V/RPM]

- e.g. KE= 0.01, 0.05, or 0.1

KT : Torque constant [Lb-in/A]

- e.g. KT= 0.1, 0.5, or 1

※ 1 Pound Inch equals 0.11 Nm

- From the 3-Phase Induction Motor specification, the model is characterized by setting parameters LL, RLL, KE, KT and LOAD.

2) Simulation Circuit of 3-Phase AC Motor Model

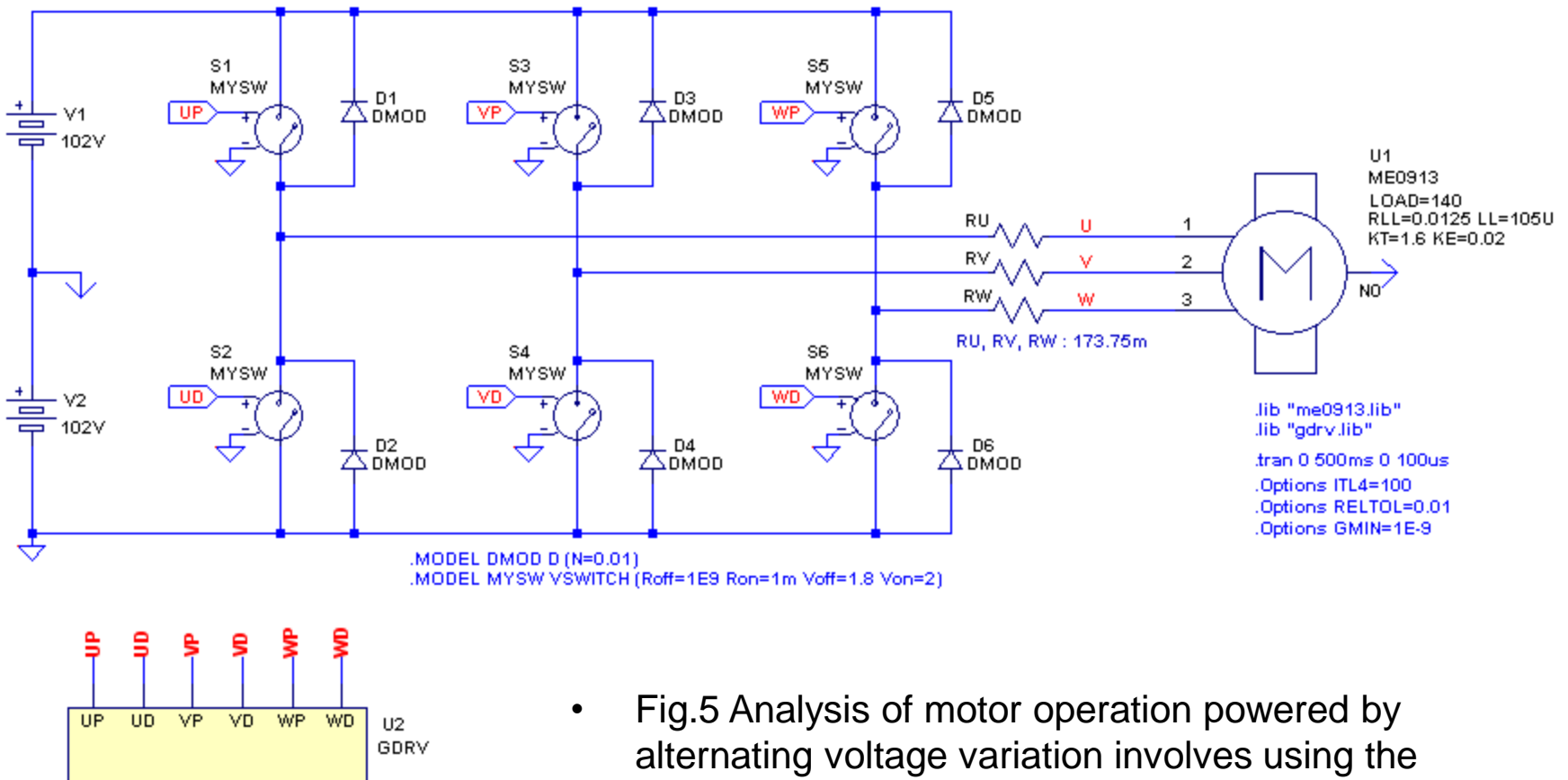

- Fig.5 Analysis of motor operation powered by alternating voltage variation involves using the model of three-phase induction motor.

2.1) Phase Current Characteristics Under Load Variation - Simulation Results

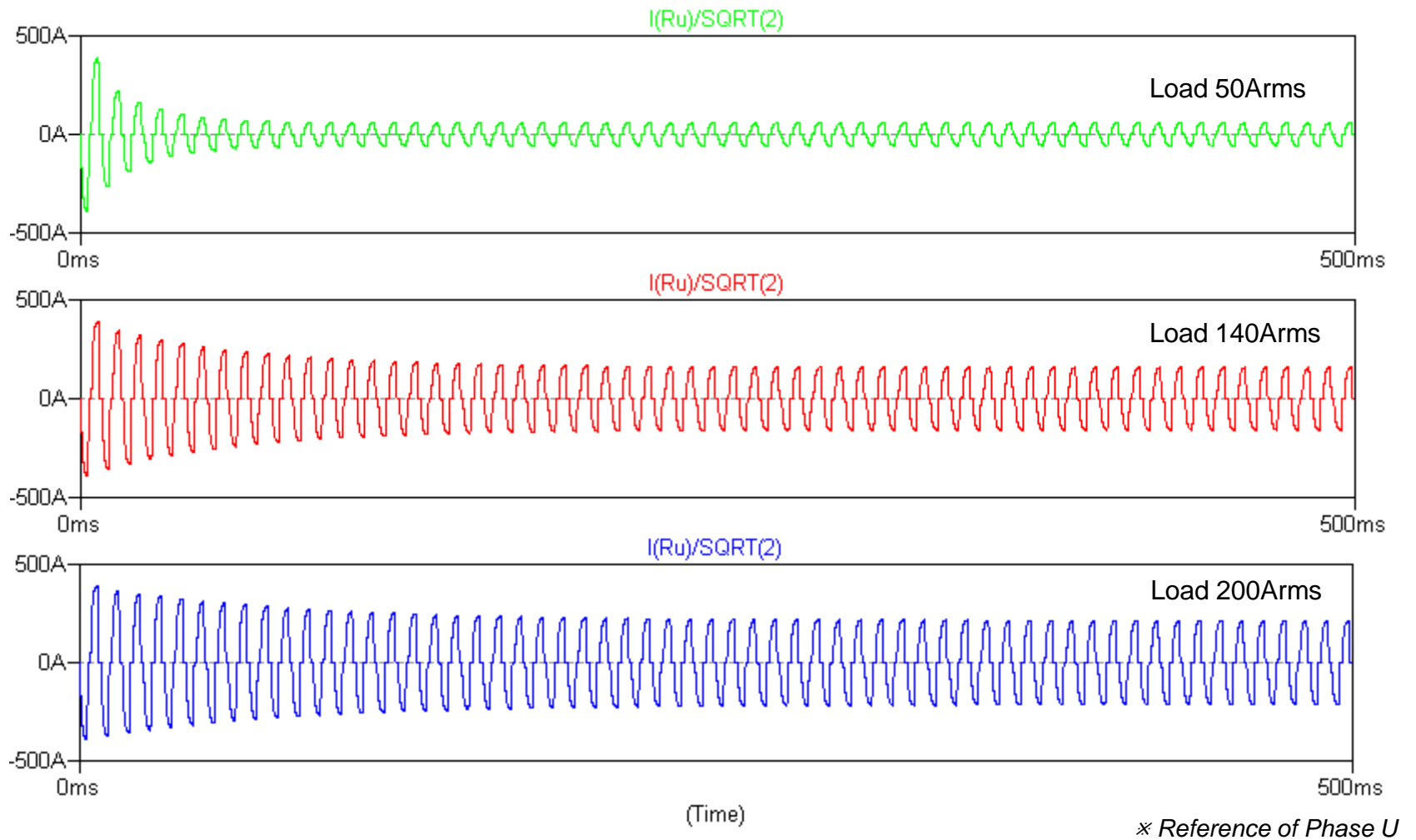

Fig. 6 Current Characteristics under load Condition

2.2) Back-EMF Characteristics Under Load Condition - Simulation Results

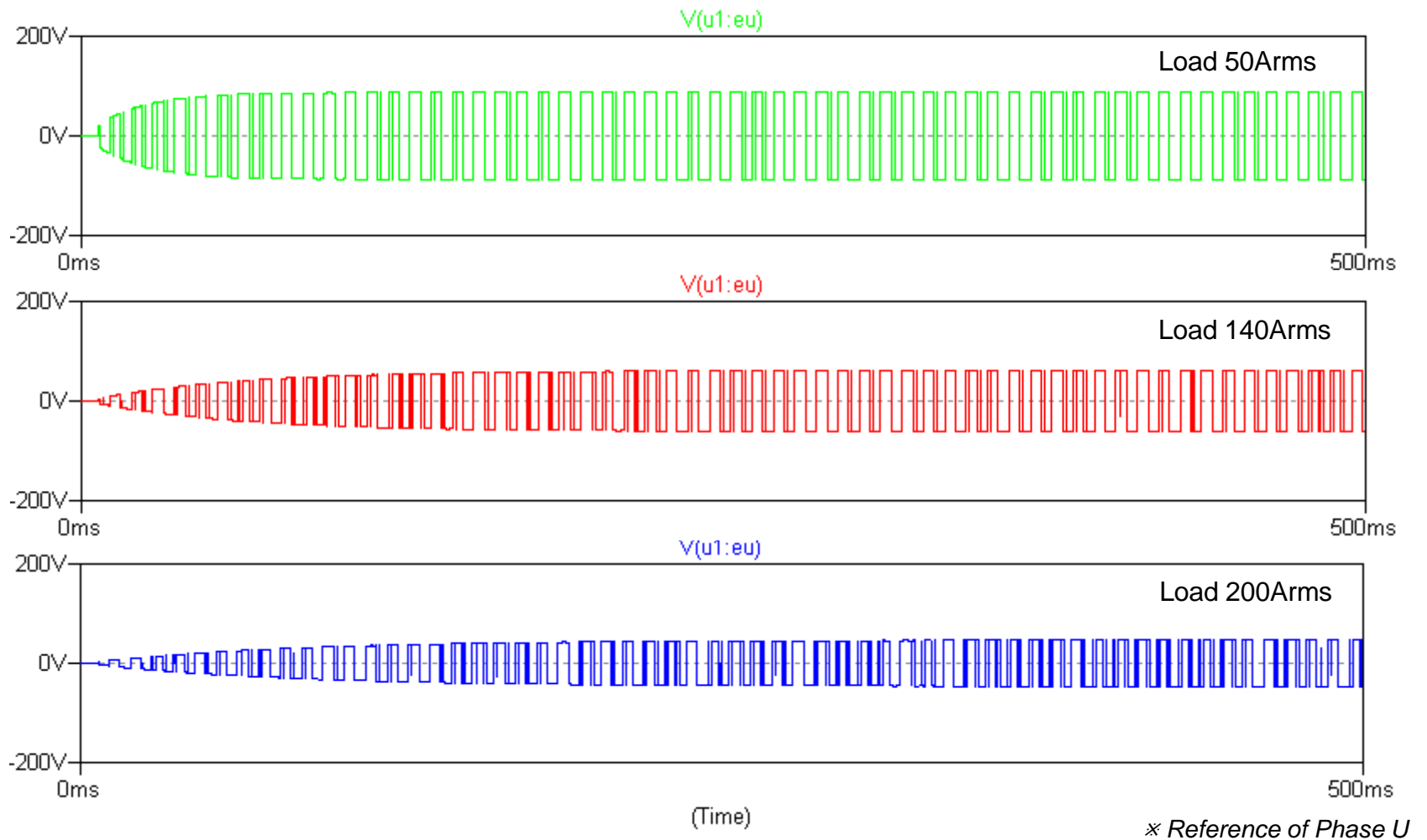

Fig. 7 Back-EMF Characteristics under load Condition

2.3) Speed and Torque Characteristics At 140Arms - Simulation Results

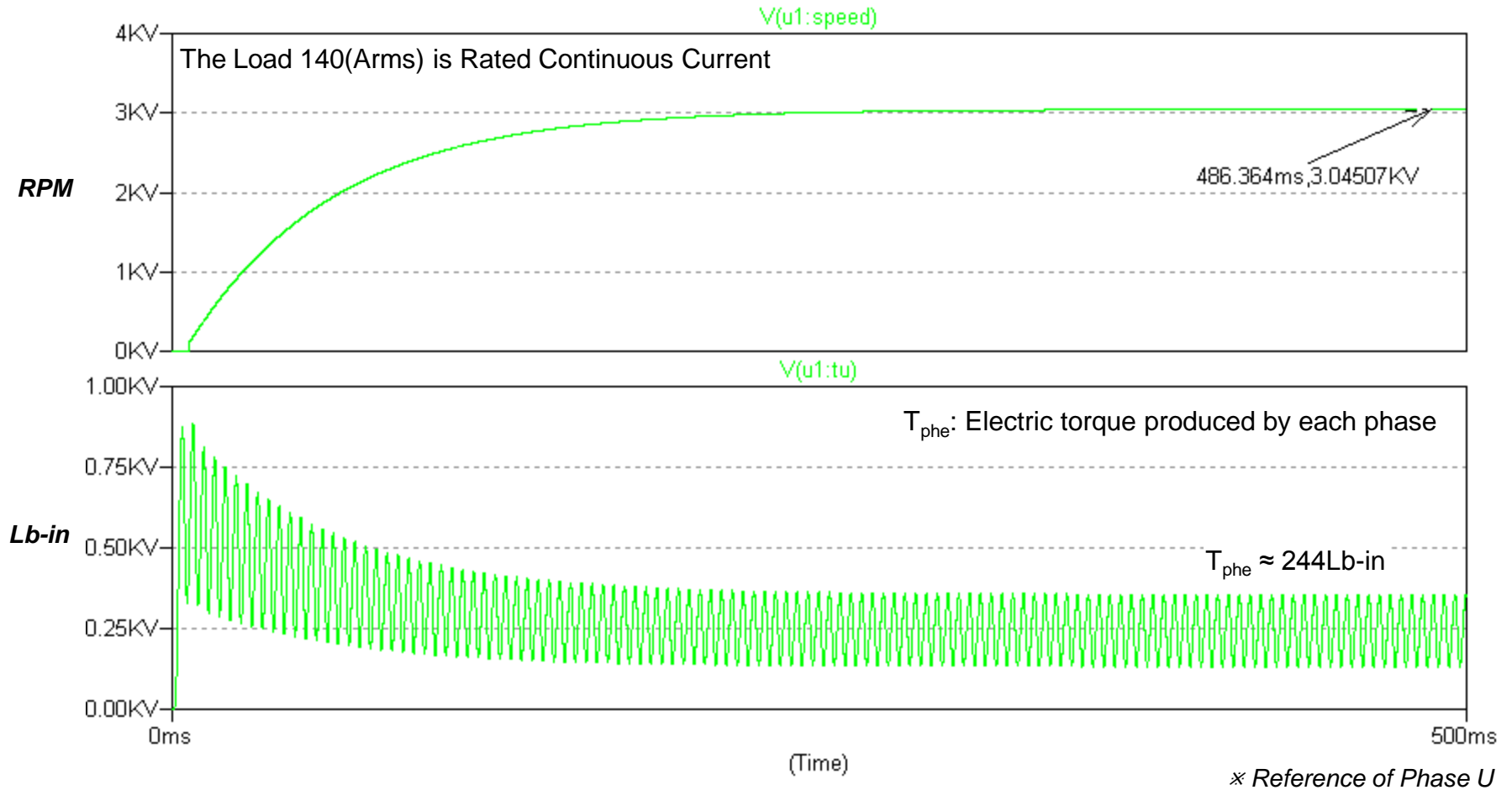

Fig. 8 Speed and Torque Characteristics at Load=140Arms